

Superior Solutions for Sheet Metal Fabricators

# LONGLIFE™ SLITTING TOOL SYSTEM

For Trumpf™ Style Presses



**2016**  
PN

**WORLDWIDE HEADQUARTERS:**

1295 Lund Boulevard, Anoka, Minnesota 55303 USA  
Tel +1.763.421.0230 Fax +1.763.421.0285  
Toll Free: Tel 800.328.4492 Fax 800.541.0285  
[mate.com](http://mate.com)

**MATE**®  
**M**  
**PRECISION  
TOOLING**  
TRUSTED | QUALITY | SERVICE | SOLUTIONS

# LOGLIFE™ SLITTING TOOL SYSTEM FOR TRUMPF™ STYLE PRESSES

Mate's LongLife™ slitting tool system for Trumpf style punch presses is designed to deliver exceptional value combining premium tool steel punch and die inserts with robust punch and die holders. Fully OEM compatible, Mate LongLife provides you with the most cost-effective slitting tool solution.

## PUNCH INSERT

- LongLife™ Premium M4PM™ high speed steel provides maximum interval between regrinds and improves piece part quality
- Available in four standard shapes: rectangle, oval, dovetail and trapezoid
- Metric and inch sizes:
  - Size 56 0.787(19,98) to 2.200(55,88)
  - Size 76 2.206(56,01) to 2.995(76,08)
- Widths up to 0.250(6,35)
- Optional Maxima™ coating available
- Compatible with Trumpf style



## PUNCH HOLDER

- LongLife™ tool system offers two styles of punch holders:
  - Integral alignment ring for fast, precise tool set up
  - Separate heavy duty alignment ring (additional) to allow manual angle setting flexibility
- Works with conventional machine strippers

## DIE INSERT

- Premium M4PM™ high speed steel for high wear resistance and exceptional die strength
- Metric and inch sizes:
  - Size 56 0.787(19,98) to 2.200(55,88) 1-piece or 2-piece insert
  - Size 76 0.787(19,98) to 2.995(76,08) 1-piece or 2-piece insert
- Widths up to 0.250(6,35)
- 11 standard discrete die clearances:
  - 0.004(0,10) to 0.024(0,60) in 0.002(0,05) increments
- Compatible with Trumpf style

## DIE HOLDER ASSEMBLY

- Includes full shim set with two thicknesses
- Two sizes:
  - Size 56 for up to .250 x 2.200(6,35 x 55,88)
  - Size 76 for up to .250 x 2.995(6,35 x 76,08)



[Dimensions in Inches(mm)]

# LOGLIFE™ SLITTING TOOL SYSTEM FOR TRUMPF™ STYLE PRESSES

## ORDER GUIDE

| Punch Insert  | Part Number              |     |
|---|--------------------------|-----|
| Size 56<br>0.787(19,98) to 2.200(55,88)   | PPDE_A                   |     |
| Size 76<br>2.206(56,01) to 2.995(76,08)   | PPDF_A                   |     |
| <b>Punch Holder</b>   |                          |     |
| Without alignment ring  | PPD2HA                   |     |
| With integral alignment ring  | PPD2HAVANTF              |     |
| <b>Die Insert</b><br><small>(Note: when ordering an oval punch insert, the die insert must be a rectangle with radius corners.)</small> |                          |     |
| Size 56<br>0.787(19,98) to 2.200(55,88)   | DSDE*_<br>1-piece insert |     |
| Size 56<br>0.787(19,98) to 2.200(55,88)   | DTDE*_<br>2-piece insert |     |
| Size 76<br>0.787(19,98) to 2.995(76,08)   | DSDF*_<br>1-piece insert |     |
| Size 76<br>0.787(19,98) to 2.995(76,08)   | DTDF*_<br>2-piece insert |     |
| <b>Die Holder Assembly</b>  |                          |     |
| For up to .250 x 2.000(6,35x55,88)  | DPD2H056                 |     |
| For up to .250 x 2.995(6,35x76,08)  | DPD2H076                 |     |
| <b>Replacement of Die Shims</b>   |                          |     |
| 5,00 x 55,88 .012(0,30mm) thick   | MATE01326                |     |
| 5,00 x 55,88 .020(0,51mm) thick   | MATE01327                |     |
| 5,00 x 76,08 .012(0,30mm) thick   | MATE01328                |     |
| 5,00 x 76,08 .020(0,51mm) thick   | MATE01329                |     |
| <b>Options</b>  |                          |     |
| Standard Solid Size 2 Die,<br>rectangle or oval only  | DOT2*_                   |     |
| Maxima™ coating for punches   |                          | ADD |

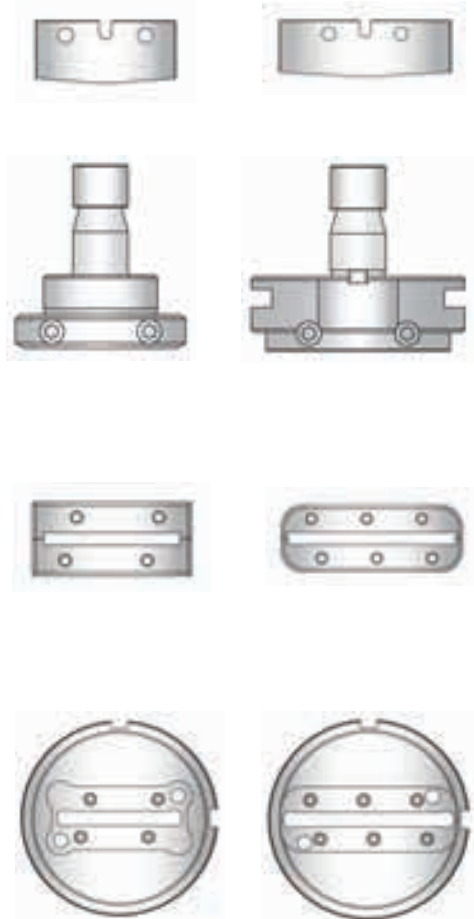

### \* STANDARD SHAPES

Rectangle      Oval

Use 1

Use 2

Trapezoid

Dovetail

Use T

Use V

**NOTE:** Trumpf-manufactured inserts at maximum length are actually 0,12mm shorter than indicated on the product. If the Trumpf product lists as 56,00mm, it is actually 55,88mm. If the Trumpf product lists as 76,20mm, it is really 76,08mm.

**PRODUCT ALERT!:** You will incur a significant upcharge if you order an actual 56,00mm or 76,20mm insert and Mate will not guarantee such product. Consult a Mate Customer Service representative for additional information and specific pricing.

[Dimensions in Inches(mm)]





visit [mate.com](http://mate.com)

## **MATE PRECISION TOOLING**

### **WORLDWIDE HEADQUARTERS:**

1295 Lund Boulevard, Anoka, Minnesota 55303 USA  
Tel +1.763.421.0230 Fax +1.763.421.0285 [mate.com](http://mate.com)

© The Mate Logo is a registered trademark of Mate Precision Tooling Inc.  
LongLife, M4PM, and Maxima are trademarks of Mate Precision Tooling Inc.  
Trumpf is a tradename of TRUMPF Inc. (Subsidiary of TRUMPF GmbH & Co. KG.)